

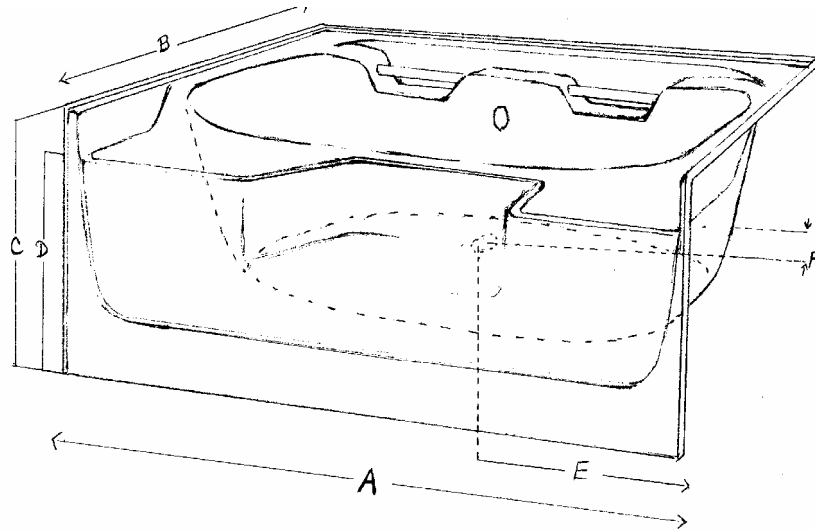

**Model AUGUSTA 48**  
Fiberglass Garden Tub

**Nominal Sizes: 60" x 48"**



**Features:**

- ◆ Center drain
- ◆ Dual grab bars
- ◆ Sloped backrest
- ◆ Integral front apron
- ◆ Slip resistant bottom
- ◆ Slip resistant step
- ◆ High gloss finish
- ◆ Whirlpool option
- ◆ **Removable access panel**

**Unit Dimensions (Tolerances + or - 1/4")**

	Finished	Rough
A	58 1/2"	59 1/2"
B	47"	48"
C	23"	24"
D	18"	
E	29 1/2"	
F	11"	

**Best Warranty in the Business**

Spurlin Industries warrants each unit against defects in materials and workmanship which may alter the appearance or affect performance of your unit for a full 5 years. Spurlin will repair, refinish, or replace any defective unit to ensure your complete satisfaction.

**Certified Compliance with Standards**

Spurlin Industries' fiberglass bathroom fixtures display the certification label of the Universal Laboratory, Inc. File No. 19451 which demonstrates compliance with ANSI Z124.1 & Z124.2 and with HUD/FHA UM-73. Certification is based on regular inspection and testing at each plant of fabrication.

**Setting Tomorrow's Standards Today**

Spurlin Industries fiberglass bath fixtures not only exceed industry standards but must also pass our own supreme standards of excellence. Each unit is manufactured to exacting specifications with strict attention to detail and quality.

Certification labels also verify compliance with the requirements for Class B material under NFPA Number 101 and with the Minimum Property Standards for Care Type and elderly housing.